

SPORTJET 435

LENGTH O.A.	4.35m (±1%)
BEAM O.A.	1.94m (±1%)
DRAFT (FULLY LOADED)	0.36m
ENGINE	ROTAX 903/ 1503
POWER	90/ 150hp ≅ 67/ 112kW
DRY WEIGHT	435Kg/ 480Kg
SEATING CAPACITY	7
FUEL	PETROL
FUEL CAPACITY	60L
MAX. SPEED	41/ 52mph ≅ 66/ 83kph
No. TUBE COMPARTMENTS	5
CE DESIGN CATEGORY	C

NOTES:

1. LENGTH / BEAM TOLERANCE DUE TO VARIATION IN TUBE PRESSURE.
2. AVERAGE DRY WEIGHT STATED; ACTUAL WEIGHT DEPENDENT ON OPTIONS FITTED.
3. LOW PROFILE SPEC:
-DEFLATE TUBES
-REMOVE STEERING WHEEL, QUICK RELEASE OPTION REQUIRED.
4. STANDARD CHOCKS*: 99-0405
CHOCK PROFILES DRAWING: RD1016

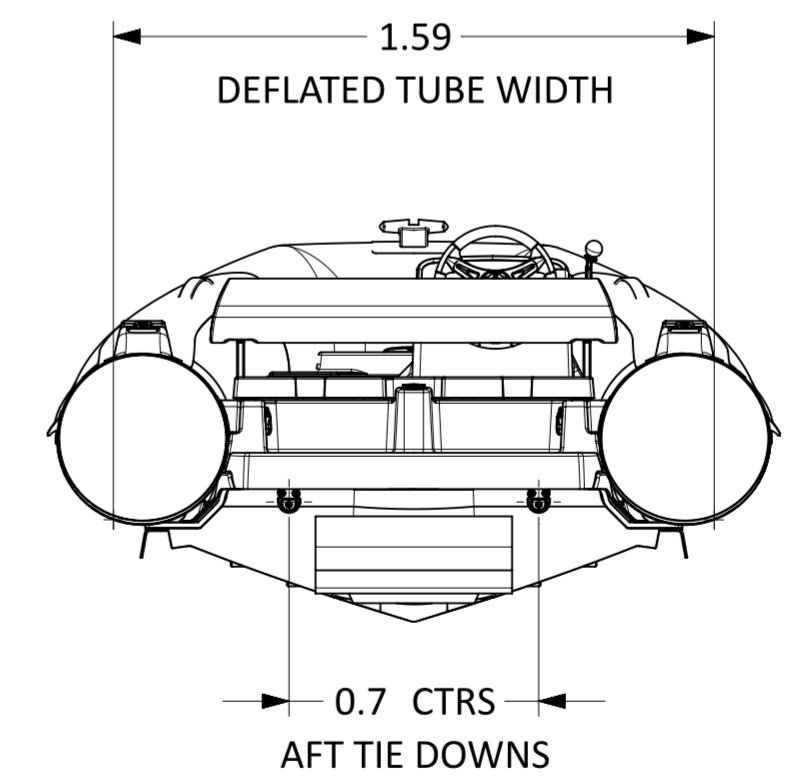
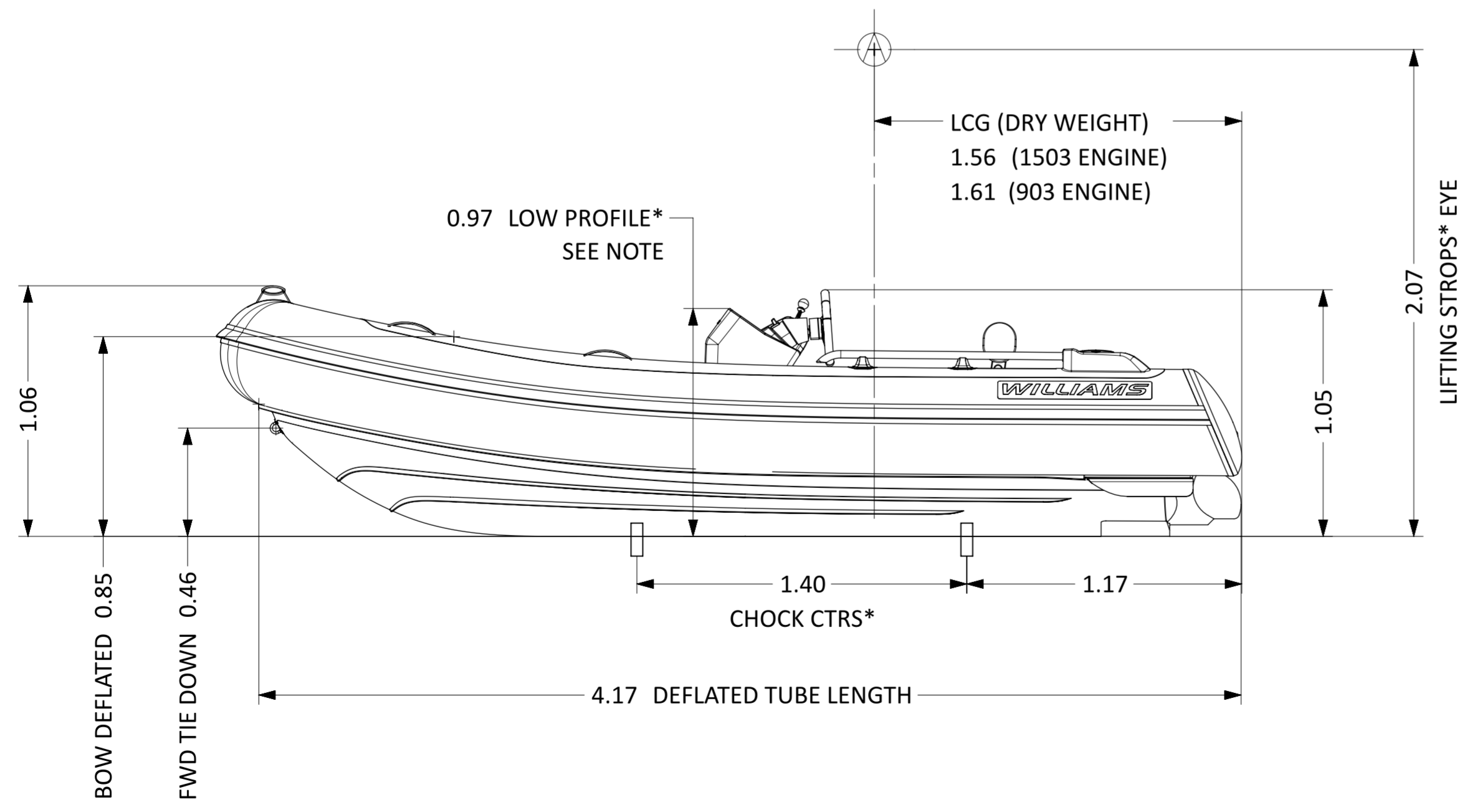
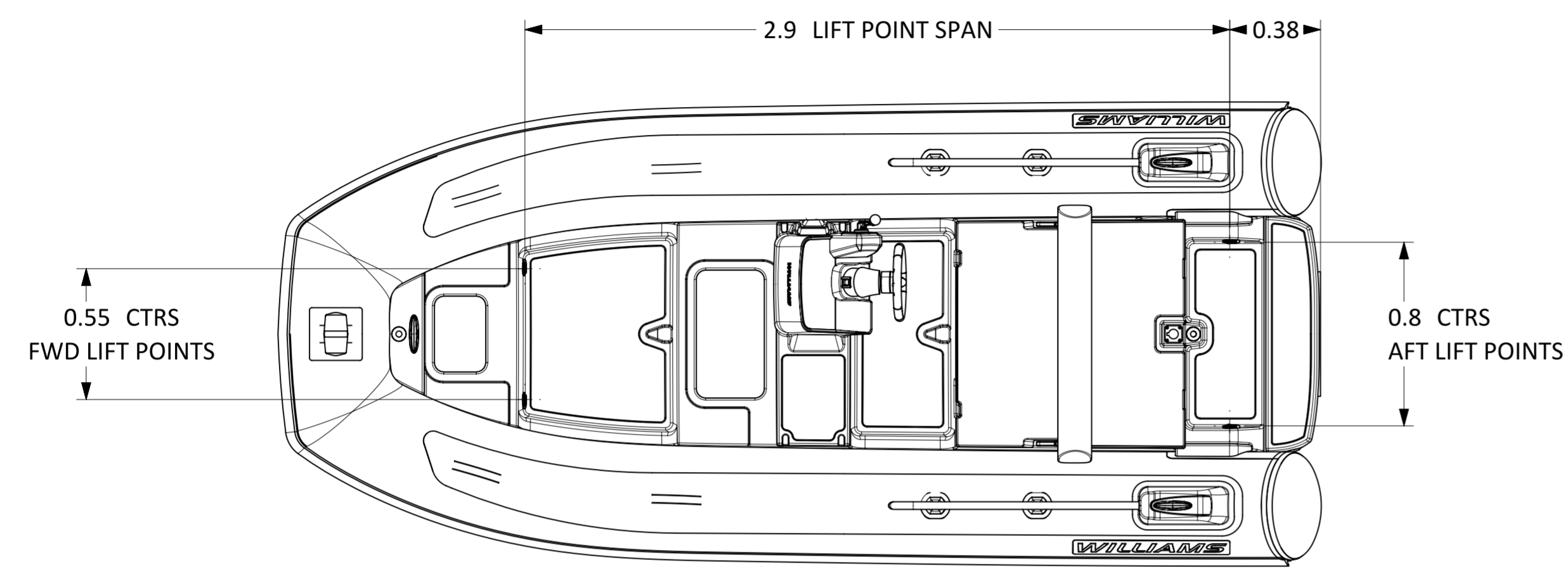

*OPTIONAL ACCESSORY

REV.	DATE	DETAILS	GT	DBS
1	22/08/18	PRODUCTION RELEASE	GT	DBS

NOT FOR PUBLICATION - THIS DRAWING IS THE PROPERTY OF WILLIAMS PERFORMANCE TENDERS LTD. AND IS ISSUED ON CONDITION THAT IT IS NOT COPIED, RE-PRINTED OR DISCLOSED EITHER WHOLLY OR IN PART TO ANY THIRD PARTY NOT AUTHORISED TO RECEIVE IT

DRAWN	GT	DATE	22/08/18
APPVD	DBS	DATE	22/08/18
PROJECT:	-		
INSPECTION LEVEL:	-		
MATERIAL & FINISH	-		
GENERAL SURFACE FINISH	Ra 1.6UM		
DO NOT SCALE DRAWING			

WILLIAMS

TITLE
SPORTJET 435 (2019MY)

PART NO.
WPT-000435SJ-2019MY-DATASHEET-dwg.1

SCALE 1:20

SHEET 1 OF 1