

OCEAN MASTER 460

SPECIFICATIONS

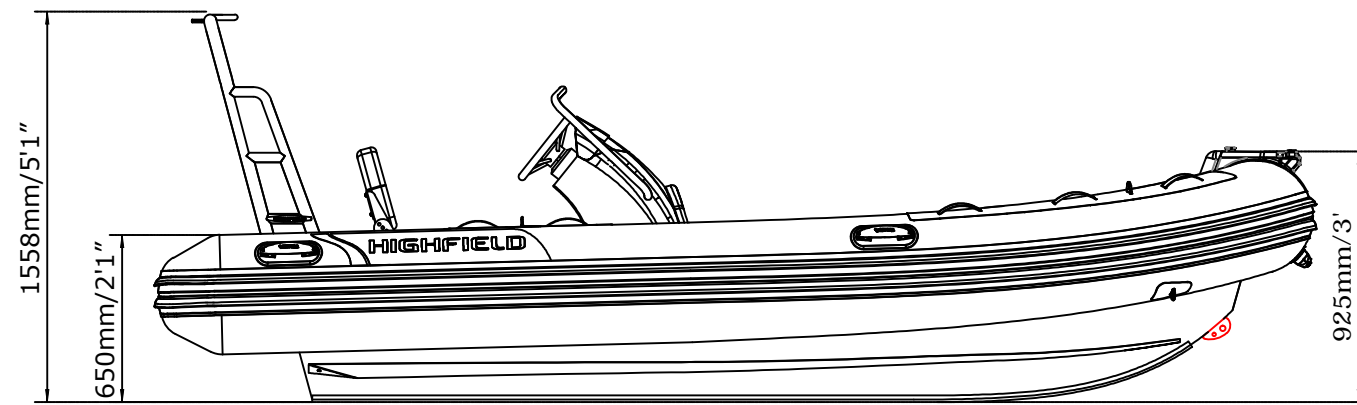

Side View

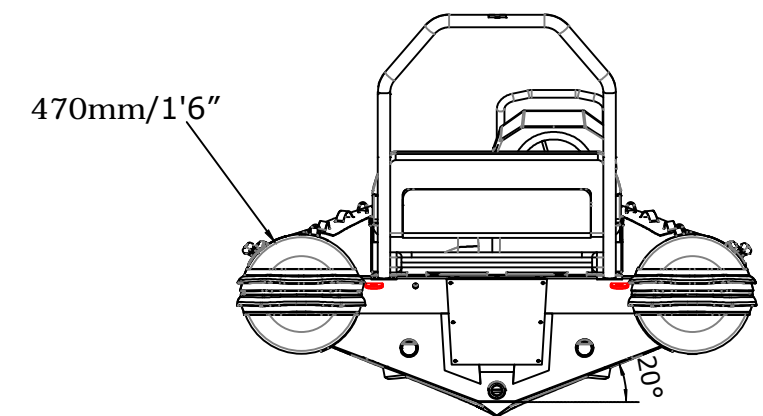

Rear View

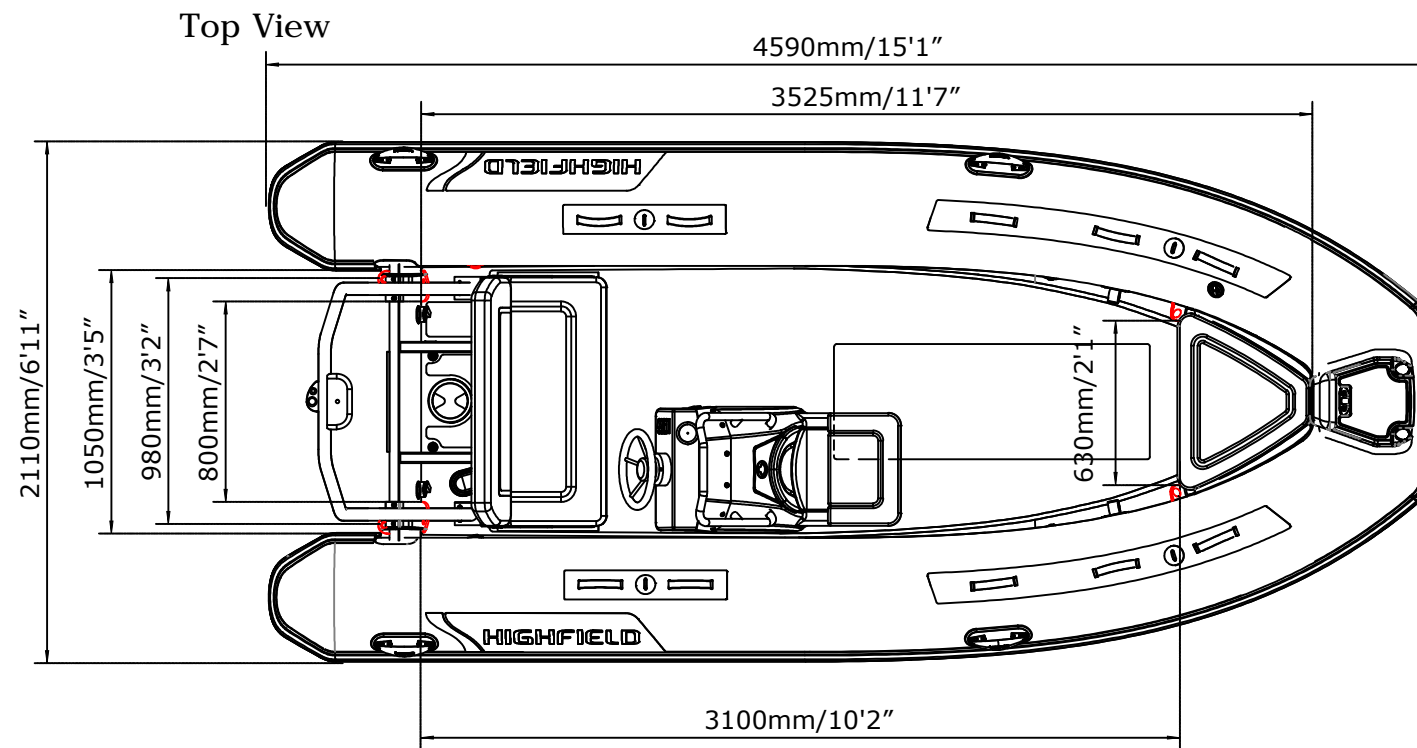

Top View

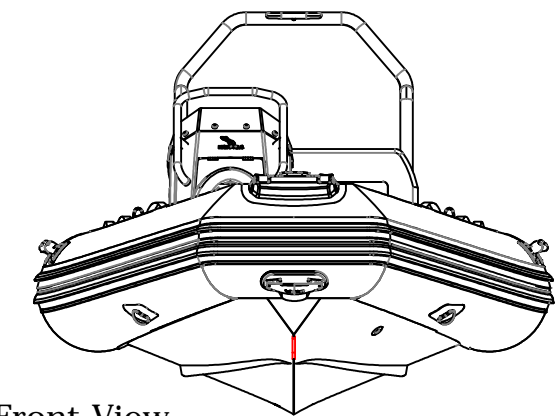

Front View

MODEL	ISO 6185 PART	ISO 6185															Wet Weight (Approximate) 80HP (60KW) + Fuel		AIR CHAMBERS					
			KG	LB	#	KG	LB	Length	KG	LB	Maximum		Recommended		Maximum Speed			KG		LB	KG	LB	PSI	BAR
OM460	3	C	944	2081	9	675	1488	L	207.6	458	59.68	80	37.3	50	/	/	/	296	653	531.6	1172	5	3.63	0.25

Weight includes: console ,seat ,rollbar